

# GS1 Series Introduction



GS1 Series Drives					
Motor Rating	Hp	.25	.5	1	2
	kW	0.2	0.4	0.75	1.5
115 Volt Single-Phase Input/230 Volt Three-Phase Output	✓	✓			
230 Volt Single-Phase Input/230 Volt Three-Phase Output	✓	✓	✓		
230 Volt Three-Phase Input/Output					✓

## Overview

The GS1 series of AC drives is our most affordable and compact inverter, offering V/Hz control with general purpose application features. These drives can be configured using the built-in digital keypad (which also allows you to set the drive speed, start and stop, and monitor specific parameters) or with the standard RS-485 serial communications port. Standard GS1 features include one analog input, four programmable digital inputs and one programmable normally open relay output.

## Features

- Simple Volts/Hertz control
- Pulse Width Modulation (PWM)
- 3 - 10 kHz carrier frequency
- IGBT technology
- 130% starting torque at 5Hz
- 150% rated current for one minute
- Electronic overload protection
- Stall prevention
- Adjustable accel and decel ramps
- S-curve settings for acceleration and deceleration
- Manual torque boost
- Automatic slip compensation
- DC braking
- Built-in EMI filter
- Three skip frequencies
- Trip history
- Integral keypad and speed potentiometer
- Programmable jog speed
- Three programmable preset speeds
- Four programmable digital inputs
- One programmable analog input
- One programmable relay output
- RS-485 Modbus communications up to 19.2K
- Optional Ethernet communications
- UL/cUL/CE listed

## Accessories

- AC line reactors
- RF filter
- Ethernet interface
- Four and eight port RS-485 multi-drop termination board
- KEPCON Direct I/O Server
- GSoft drive configuration software
- GS-485HD15-CBL - ZIPlink RS485 Communication cable for connection to the DL06 and D2-260 15-pin ports.

*Detailed descriptions and specifications for the accessories are available in the "GS/DURApulse Accessories" section.*

## Typical Applications

- Conveyors
- Fans
- Pumps
- Shop tools

## GS1 series part numbering system

GS1 - 2 0P5

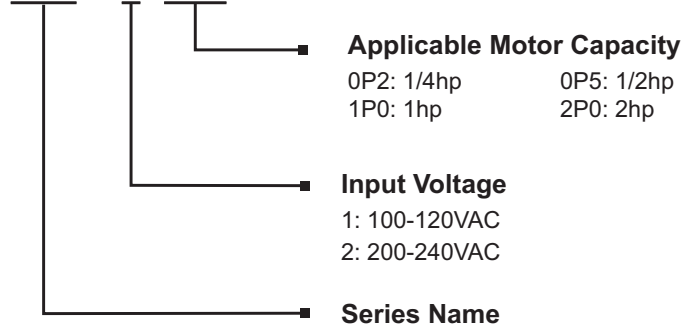

# GS1 Series Specifications

115V/230V CLASS GS1 Series							
Model	GS1-10P2	GS1-10P5	GS1-20P2	GS1-20P5	GS1-21P0	GS1-22P0	
Price	<--->	<--->	<--->	<--->	<--->	<--->	
Motor Rating	HP	1/4 hp	1/2 hp	1/4 hp	1/2 hp	1hp	2hp
	kW	0.2 kW	0.4 kW	0.2 kW	0.4 kW	0.7 kW	1.5 kW
Rated Output Capacity (200V) kVA	0.6	1.0	0.6	1.0	1.6	2.7	
Rated Input Voltage	Single-phase 100-120 VAC $\pm 10\%$ , 50/60 Hz $\pm 5\%$		Single/three-phase: 200-240 VAC $\pm 10\%$ , 50/60 Hz $\pm 5\%$			Three-phase: 200-240 VAC $\pm 10\%$ , 50/60 Hz $\pm 5\%$	
Rated Output Voltage	Three-phase corresponds to double the input voltage		Three-phase corresponds to the input voltage				
Rated Input Current (A)	6	9	4.9/1.9	6.5/2.7	9.7/5.1	9	
Rated Output Current (A)	1.6	2.5	1.6	2.5	4.2	7.0	
Watt Loss @ 100% I (W)	19.2	19.2	18.4	26.8	44.6	73	
Weight: kg (lb)	2.10	2.20	2.20	2.20	2.20	2.20	
Dimensions (HxWxD) (mm [in])	132.0 x 68.0 x 128.1 [5.20 x 2.68 x 5.04]						
Accessories							
Ethernet Communications module for GS Series Drives (DIN rail mounted)	GS-EDRV						
Four port RS-485 multi-drop termination board	GS-RS485-4						
Eight port RS-485 multi-drop termination board	GS-RS485-8						
Software	GSoft / KEP <i>Direct</i>						
OPC Server	KEP <i>Direct</i>						

# GS1 General Specifications

General Specifications			
<b>Control Characteristics</b>			
<b>Control System</b>	Sinusoidal Pulse Width Modulation, carrier frequency 3kHz - 10kHz		
<b>Rated Output Frequency</b>	1.0 to 400.0 Hz limited to 9999 motor rpm		
<b>Output Frequency Resolution</b>	0.1 Hz		
<b>Overload Capacity</b>	150% of rated current for 1 minute		
<b>Torque Characteristics</b>	Includes manual torque boost, auto-slip compensation, starting torque 130% @ 5.0Hz		
<b>DC Braking</b>	Operation frequency 60-0Hz, 0-30% rated voltage. Start time 0.0-5.0 seconds. Stop time 0.0-25.0 seconds		
<b>Acceleration/Deceleration Time</b>	0.1 to 600 seconds (can be set individually)		
<b>Voltage/Frequency Pattern</b>	V/F pattern adjustable. Settings available for Constant Torque - low and high starting torque, Variable Torque - low and high starting torque, and user configured		
<b>Stall Prevention Level</b>	20 to 200% or rated current		
<b>Operation Specification</b>			
<b>Inputs</b>	<b>Frequency Setting</b>	<b>Keypad</b>	Setting by <UP> or <DOWN> buttons or potentiometer
		<b>External Signal</b>	Potentiometer - 5k $\Omega$ 0.5W, 0 to 10 VDC (input impedance 47k $\Omega$ ), 0 to 20 mA / 4 to 20 mA (input impedance 250 $\Omega$ ), Multi-function inputs 1 to 3 (3 steps, JOG, UP/DOWN command), RS485 communication setting
	<b>Operation Setting</b>	<b>Keypad</b>	Setting by <RUN>, <STOP> buttons
		<b>External Signal</b>	DI1, DI2, DI3, DI4 can be combined to offer various modes of operation, RS485 communication port
<b>Outputs</b>	<b>Multi-Function Input Signal</b>		Multi-step selection 0 to 3, Jog, Accel/decel inhibit, First/second accel/decel switch, Counter, PLC operation, External base block (N.C., N.O.) selection
	<b>Multi-Function Output Signal</b>		AC drive operating, Frequency attained, Non zero speed, Base Block, Fault indication, Local/remote indication, PLC operation indication
	<b>Operating Functions</b>		Automatic voltage regulation, S-curve, Over-voltage stall prevention, DC braking, Fault records, Adjustable carried frequency, Starting frequency setting of DC braking, Over-current stall prevention, Momentary power loss restart, Reverse inhibition, Frequency limits, Parameter lock/reset
<b>Protective Functions</b>			Overcurrent, overvoltage, undervoltage, electronic thermal motor overload, Overheating, Overload, Self testing
<b>Operator Interface</b>	<b>Operator Devices</b>		5-key, 4-digit, 7-segment LED, 3 status LEDs, potentiometer
	<b>Programming</b>		Parameter values for setup and review, fault codes
	<b>Parameter Monitor</b>		Master Frequency, Output Frequency, Scaled Output Frequency, Output Voltage, DC Bus Voltage, Output Direction, Trip Event Monitor, Trip History Monitor
	<b>Key Functions</b>		RUN/STOP, DISPLAY/RESET, PROGRAM/ENTER, <UP>, <DOWN>
<b>Environment</b>	<b>Enclosure Rating</b>		Protected chassis, IP20
	<b>Ambient Operating Temperature</b>		-10° to 40°C (14°F to 104°F) w/o derating
	<b>Storage Temperature</b>		-20° to 60 °C (-4°F to 140°F) during short-term transportation period)
	<b>Ambient Humidity</b>		0 to 90% RH (non-condensing)
	<b>Vibration</b>		9.8 m/s <sup>2</sup> (1G), less than 10Hz. 5.88 m/s <sup>2</sup> (0.6G) 20 to 50 Hz
<b>Installation Location</b>			Altitude 1000m or lower above sea level, keep from corrosive gas, liquid and dust
<b>Options</b>			Programming Software (GSOFT)

# GS1 Specifications - Installation

Understanding the installation requirements for your GS1 drive will help to ensure that it will operate within its environmental and electrical limits.

**NOTE:**  
Never use only this catalog for installation instructions or operation of equipment; refer to the user manual, GS1-M.

Environmental Specifications	
<b>Protective Structure</b>	IP20
<b>Ambient Operating Temperature<sup>2</sup></b>	-10 to 40°C
<b>Storage Temperature<sup>3</sup></b>	-20 to 60°C
<b>Humidity</b>	to 90% (no condensation)
<b>Vibration<sup>4</sup></b>	5.9 m/s <sup>2</sup> (0.6g), 10 to 55 Hz
<b>Location</b>	Altitude 1,000 m or less, indoors (no corrosive gases or dust)

- 1: Protective structure is based upon EN60529
- 2: The ambient temperature must be in the range of -10° to 40° C. If the range will be up to 50° C, you will need to set the carrier frequency to 2.1 kHz or less and derate the output current to 80% or less. See our Web site for derating curves.
- 3: The storage temperature refers to the short-term temperature during transport.
- 4: Conforms to the test method specified in JIS C0911 (1984)

Watt-loss Chart	
GS1 Drive Model	At full load
GS1-10P2	19.2
GS1-10P5	19.2
GS1-20P2	18.4
GS1-20P5	26.8
GS1-21P0	44.6
GS1-22P0	73

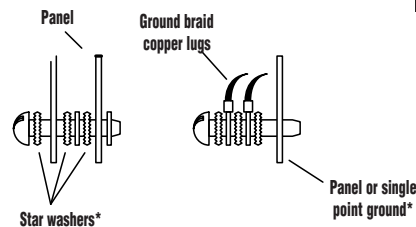
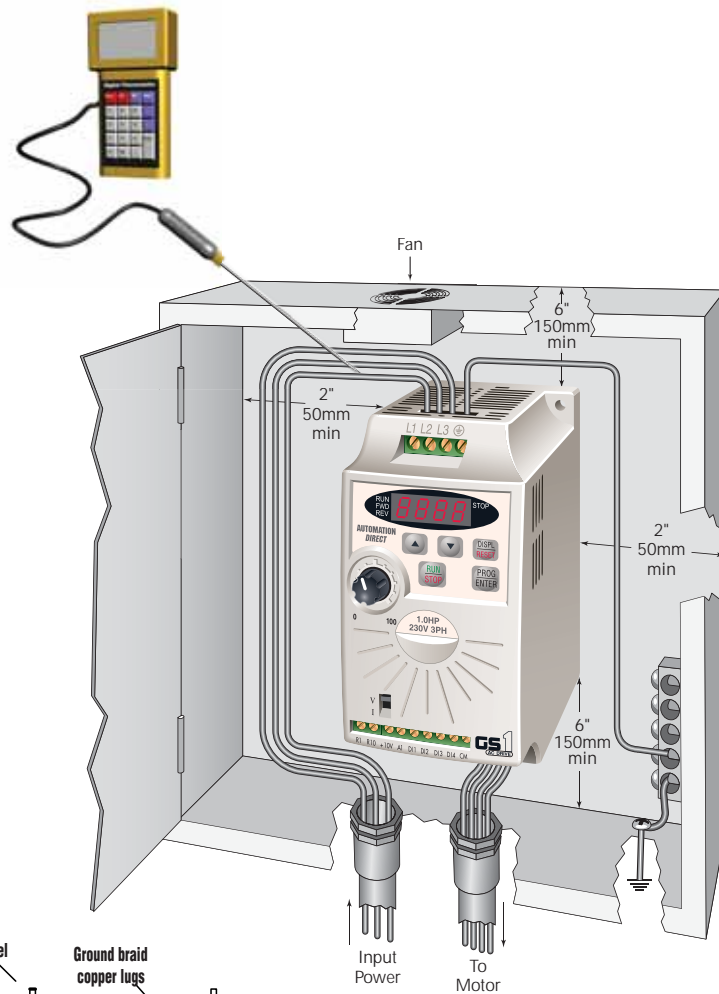

**\* FOR PAINTED SUB-PANELS, SCRAPE THE PAINT FROM UNDERNEATH THE STAR WASHERS BEFORE TIGHTENING THEM.**



**Warning:** AC drives generate a large amount of heat, which may damage the AC drive. Auxiliary cooling methods are typically required in order to not exceed maximum ambient temperatures.

# GS1 Specifications - Terminals

Main Circuit Wiring	
Terminal	Description
L1, L2, L3	Input power
T1, T2, T3	AC drive output
⊕	Ground

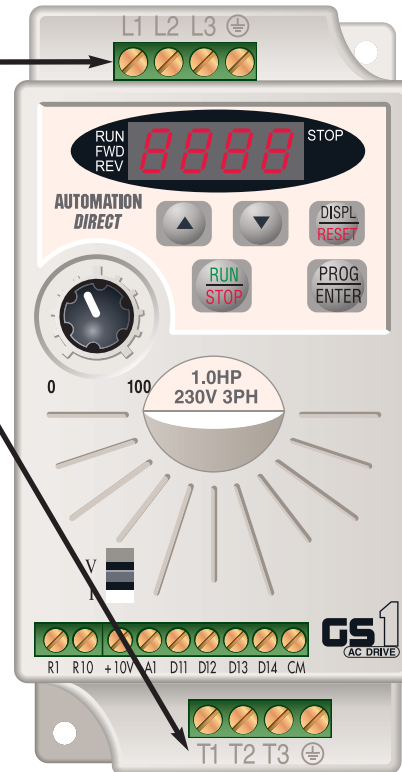
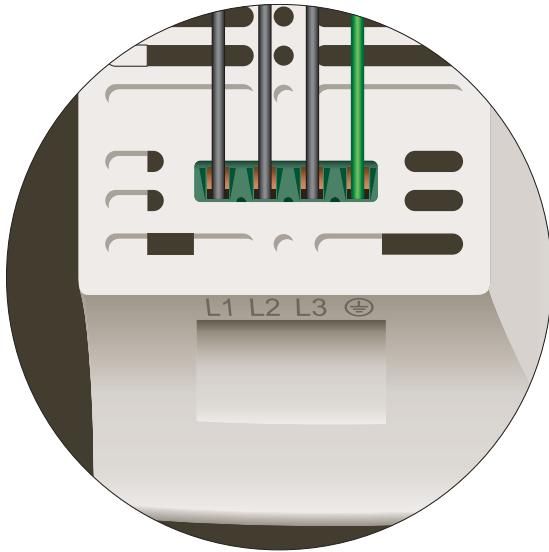

Control Circuit Terminals	
Terminal Symbol	Description
R10	Relay output 1 normally open
R1	Relay output 1 common
DI1	Digital input 1
DI2	Digital input 2
DI3	Digital input 3
DI4	Digital input 4
AI <sup>1</sup>	Analog input
+10V	Internal power supply (10 mA @ 10 VDC)
CM	Common

<sup>1</sup> 0 to +10 VDC, 0 to 20 mA, or 4 to 20 mA input represents zero to maximum output frequency.

**Note:** Use twisted-shielded, twisted-pair or shielded-lead wires for the control signal wiring. It is recommended all signal wiring be run in a separate steel conduit. The shield wire should only be connected at the drive. Do not connect shield wire on both ends.

# GS1 Specifications - Basic Wiring Diagram

**Note:** Users **MUST** connect wiring according to the circuit diagram shown below. (Refer to user manual GS1-M for additional specific wiring information.)

**Note:** Refer to the following pages for explanations and information regarding line reactors and RF filters: 13-50, 13-67.

## Power Source 3-phase\*

100-120V±10%  
(50/60Hz ±5%)  
200-240V±10%  
(50/60Hz±5%)

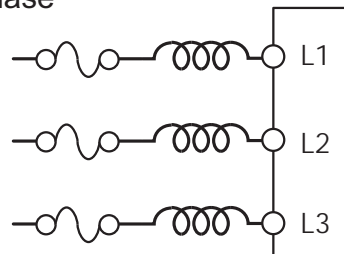

GS1-XXXX

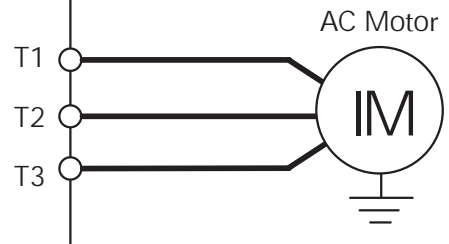

\* Use terminals L1 and L2 for 120V, or select any two of the power terminals for 240V single-phase models

Grounding resistance less than 0.1Ω

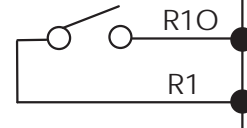
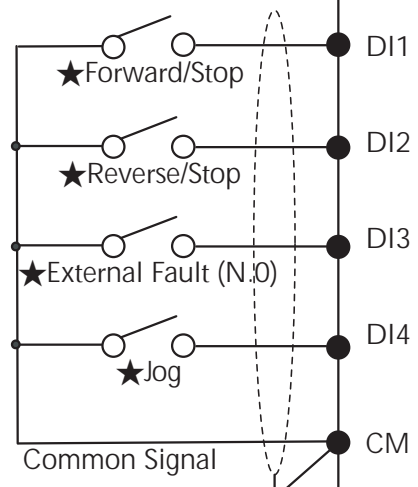

Multi-function output contacts  
120VAC/24VDC @5A  
230VAC @2.5A  
★Fault Indication

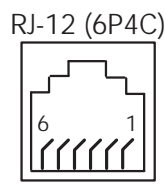

RJ-12 Serial Comm Port\*  
Interface (See Warning)

**RS-485**  
2: GND  
3: SG-  
4: SG+  
5: +5V

\*Optional ZIPLink RS485  
Communication cable GS-485HD15-CBL available for connection to the DL06 and D2-260 15-pin ports. See page 12-75.

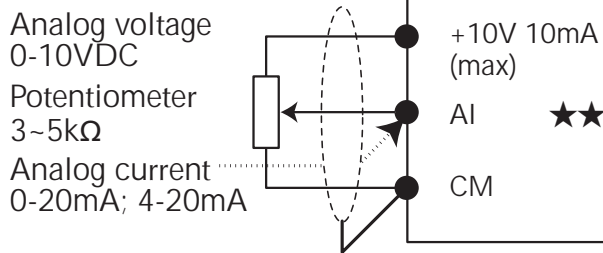

Analog voltage 0-10VDC  
Potentiometer 3~5kΩ  
Analog current 0-20mA; 4-20mA

+10V 10mA (max)  
AI ★★  
CM

★ Factory default setting

★★ Factory default source of frequency command is via the keypad potentiometer

○ Main circuit (power) terminals ● Control circuit terminal ⊕ Shielded leads



**WARNING:** Do not plug a modem or telephone into the GS1 RJ-12 Serial Comm Port, or permanent damage may result. Terminals 2 and 5 should not be used as a power source for your communication connection.

# GS1 Specifications - Dimensions

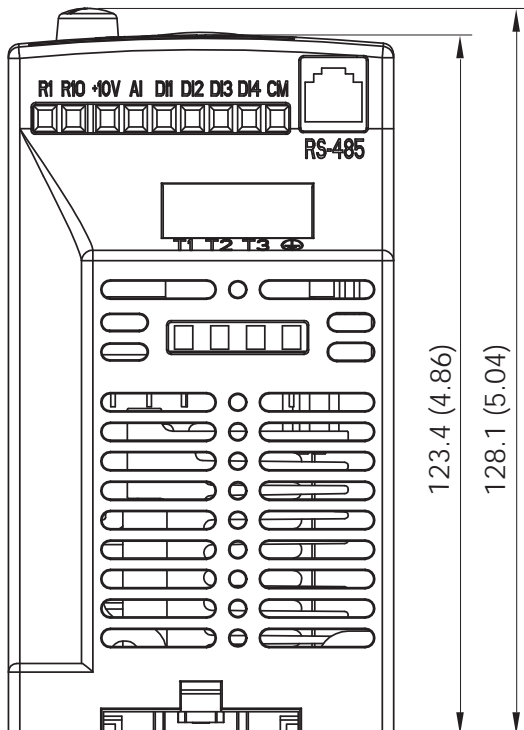
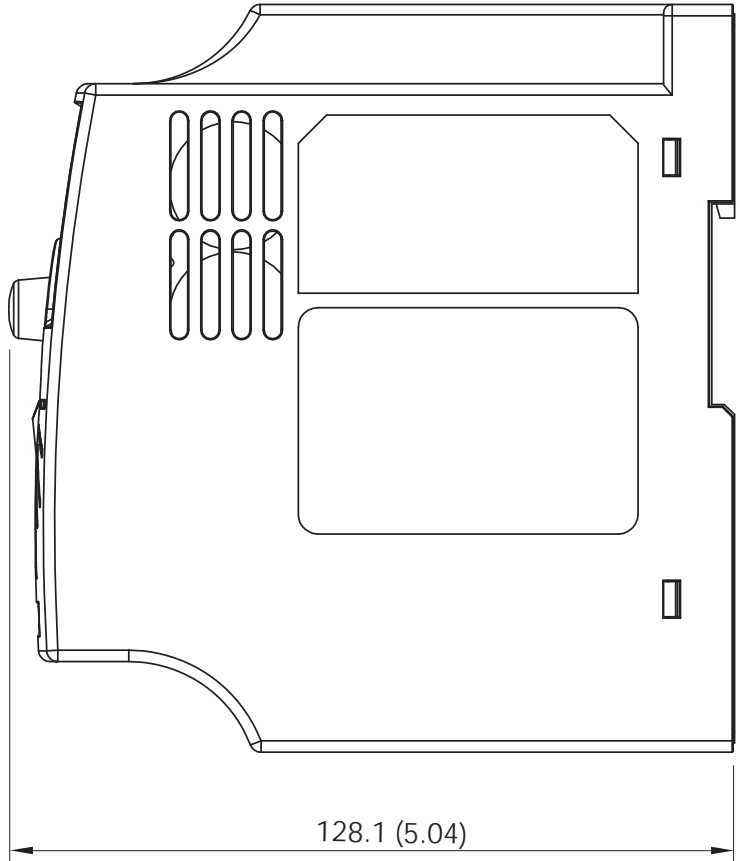
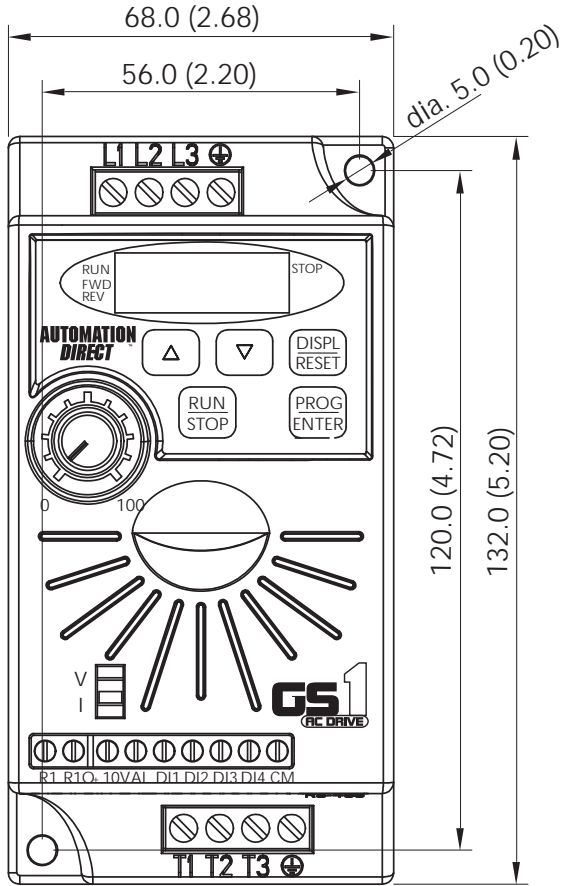

Unit: mm (in)

It is easier than you think to control the GS series and DURAPULSE drives from a DirectLOGIC or CLICK PLC when using Modbus RTU serial communications.

### Step 1: Select a Drive

Using the chart below select the drive that fits your application needs.

### Step 2: Select the Network/Protocol

Select the Network/Protocol that the drive uses.

### Step 3: Select the PLC and Communication Port

Select the PLC and Communication port that works with the drive selected.

### Step 4: Select a Cable

Select the cable (and adapter if needed) listed in the chart.

*Note: If a PLC type or PLC port is not listed in the selection charts, it does not support Modbus RTU.*

Step1	Step 3	CLICK	DL05	DL06	
		Port 2	Port 2	Port 1	Port 2
GS1	Step 2	Step 4			
	RS485 Modbus RTU	Not Possible	Not Possible	Not Possible	GS-485HD15-CBL
GS2	RS232 Modbus RTU	Not Possible	GS-RJ12-CBL-2	Not Possible	FA-15HD + GS-RJ12-CBL-2
	RS485 Modbus RTU	Not Possible	Not Possible	Not Possible	GS-485HD15-CBL
DuraPulse	RS485 Modbus RTU	Not Possible	Not Possible	Not Possible	GS-485HD15-CBL

Step1	Step 3	D2-250-1	D2-260		D4-450
		Port 2	Port 1	Port 2	Port 1
GS1	Step 2	Step 4			
	RS485 Modbus RTU	Not Possible	Not Possible	GS-485HD15-CBL-2	Not Possible
GS2	RS232 Modbus RTU	FA-15HD + GS-RJ12-CBL-2	Not Possible	FA-15HD + GS-RJ12-CBL-2	FA-CABKIT + GS-RJ12-CBL-2
	RS485 Modbus RTU	Not Possible	Not Possible	GS-485HD15-CBL-2	Not Possible
DuraPulse	RS485 Modbus RTU	Not Possible	Not Possible	GS-485HD15-CBL-2	Not Possible

ZIPLinks Connector Modules specifications begin on page 26-56

ZIPLinks Cables specifications begin on page 26-74



GS-RJ12-CBL-2



GS-485HD15-CBL-2



FA-15HD

- Company Info.
- PLCs
- Field I/O
- Software
- C-more & other HMI
- AC Drives**
- AC Motors
- Power Transmiss.
- Steppers/ Servos
- Motor Controls
- Proximity Sensors
- Photo Sensors
- Limit Switches
- Encoders
- Current Sensors
- Pressure Sensors
- Temp. Sensors
- Pushbuttons/ Lights
- Process
- Relays/ Timers
- Comm.
- Terminal Blocks & Wiring
- Power
- Circuit Protection
- Enclosures
- Tools
- Pneumatics
- Appendix
- Part Index