

NOTES:

- 1) 304 STN. STL. CONSTRUCTION.
- 2) ALL WELDING MIG OR TIG WATER TIGHT.
- 3) PASSIVATED FINISH.

FINAL APPROVALS	
<input type="checkbox"/>	APPROVED
<input type="checkbox"/>	APPROVED AS NOTED
<input type="checkbox"/>	REJECTED
COMPANY: _____	
SIGNED BY: _____	
TITLE: _____	
DATE: _____	

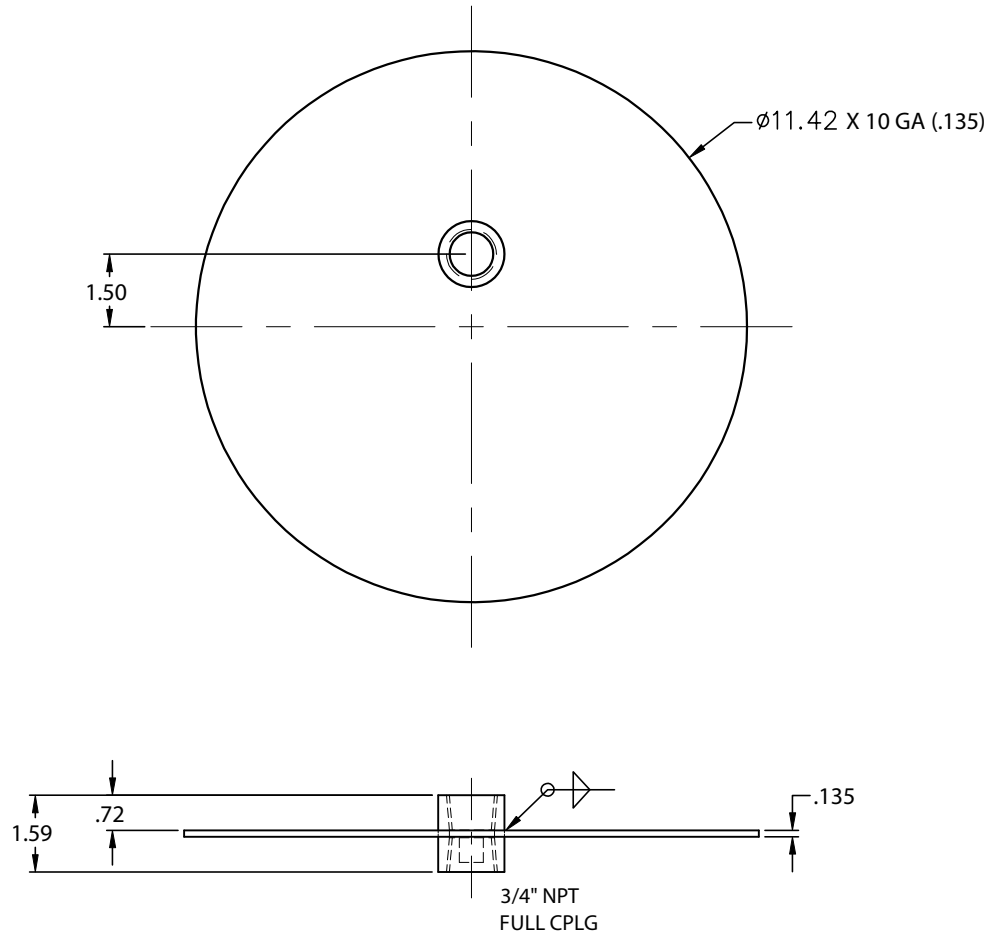

REV.	LTR.	BY	DATE	DESCRIPTION
A		RSS	2-26-08	DELETED SIX $\phi$ .22 HOLES

REVISION HISTORY

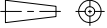
TOLERANCES UNLESS NOTED OTHERWISE		CUSTOMER	
DECIMALS DETAILS .XX $\pm$ 0.03 WLDMNT .XX $\pm$ 0.06 .XXX $\pm$ 0.010 (XX) REF.		LEON GRIFFIN	
		DESCRIPTION/DRAWING TITLE CF LID	
THIRD ANGLE PROJECTION ANGLS $\pm$ 0.5° (XX) REF.		DRAWN BY RSS	
		JOB #	
		DWG NO. REF.	DATE 2-22-08
		DRAWING # 20897102	SCALE NONE